

ECLIPSE HEAT-PAK* PACKAGED BURNERS SERIES "HP"

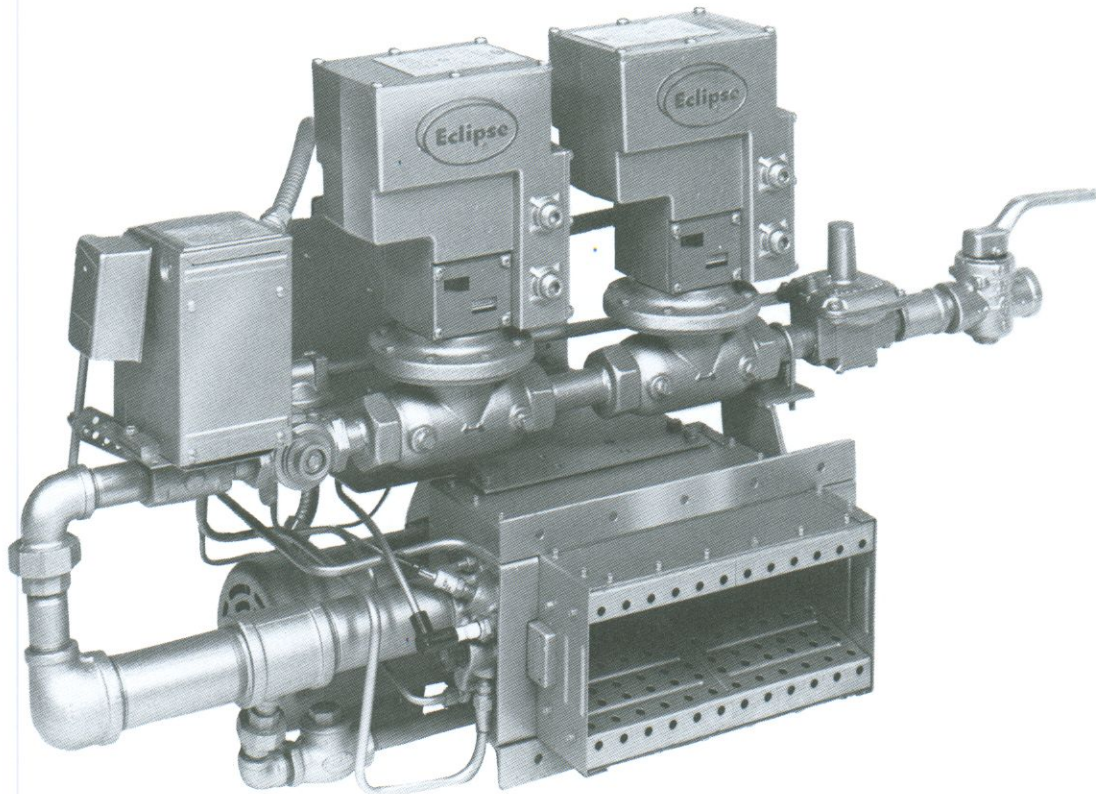

* U.S. Reissue Patent No. 26,244
Canadian Patent No. 743,782

Eclipse Heat-Pak Burners (HP) are packaged combustion systems designed primarily for heating air for industrial processes. They burn natural gas or propane vapor and produce an odorless, smokeless flame.

Heat-Pak burners are available in Standard and IRI assemblies. Standard units are completely pre-wired, pre-piped, tested and adjusted before shipment. It is necessary only to connect gas and electricity and the burner is ready for operation. To operate the burner, just turn the burner switch on or off as required.

IRI assemblies include all electrical components wired to a marked terminal strip for connection to a remote mounted control panel, available separately.

- Low NO_x, CO, and aldehydes.
- Fully packaged, easy to install and operate; optional mounting methods to suit most ducts.
- Nozzle-mix design provides excellent stability over a 40:1 turndown range.
- High duct velocities with no profiling needed.
- Integral combustion air blower.
- Integral pilot.
- Short flame length.
- Available in Standard and IRI type models.
- 100% factory tested and adjusted.



Specifications

Inputs	Burner	Btu/hr.	kW
Natural gas or propane vapor	50 HP	500,000	146.6
	100 HP	1,000,000	243.1
	150 HP	1,500,000	439.7
	200 HP	2,000,000	586.2
	250 HP	2,500,000	732.8
	300 HP	3,000,000	879.3
Flame Length:	40 to 46" (1016 to 1168 mm) at the inputs shown above.		
Maximum Turndown:	40 to 1		
Pilot Input:	Approximately 15,000 Btu/hr. (4.4 kW)		
Natural Gas Inlet Pressure:	Minimum	Maximum	
At valve train inlet	8" w.c. (20 mbar)	1 psig (69 mbar)	
Duct Pressure Limits:	Sealed Mounting:	+2" w.c. to -0.5" w.c.	+ 0.5 mbar to -1.2 mbar
	Slot Firing:	+0" w.c. to -0.5" w.c.	+ 0 mbar to -1.2 mbar
Duct Velocity:	Firing Parallel to Air Flow: 500 to 6000 fpm (2.54 to 30.48 m/s) Firing 90° to Air Flow: 500 to 1500 fpm (2.54 to 7.62 m/s)		
Max. Duct Air Temp:	1500° F (816° C)		
Ambient Temperature:	-40° to +104° F (-40° to +40° C)		
Electrical Supply:	120/1/60 standard. 230/460/3/60 optional.		
Materials:	All portions of the Heat-Pak burner exposed directly to the flame are constructed of either cast iron or #321 stainless steel.		
Packaging Options:	<p>Standard Burner: Air Heat Burner, valve train including two automatic gas shut-off valves, pressure regulator, control valve with modulating control motor, pilot regulator, pilot solenoid valve, flame monitoring relay, flame rod, air-flow switch, ignition transformer, and ignition plug, all pre-piped and pre-wired.</p> <p>IRI Type Burner: Same as standard burner but with IRI type valve train instead of standard valve train and with all electrical components wired to a marked terminal strip. High and low gas pressure switches are included. Flame monitoring relay is not included with this burner but is normally included in a remote mounted control panel which is available as a separate item. An air flow switch to prove combustion air is mounted on the burner.</p>		

Flame monitoring, valve train, and limit switch equipment supplied with these burners by Eclipse may or may not meet local safety and/or insurance requirements. The owner/user and/or his insurance underwriter must assume responsibility for the acceptance, use, and proper maintenance of flame supervision, limit controls, and other safety devices.

Typical Applications

FRESH AIR SYSTEMS

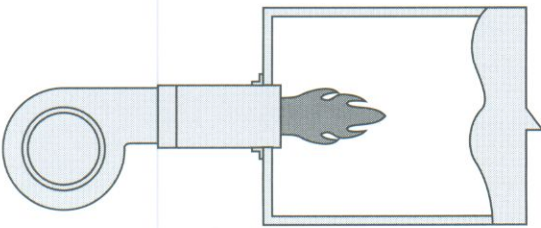

Sealed Mounting

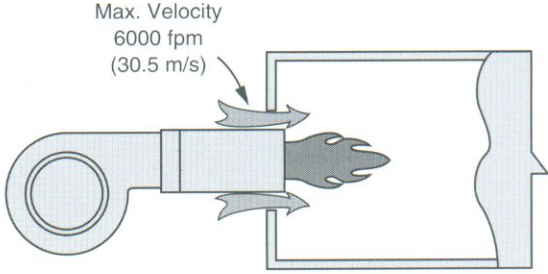

Max. Velocity
6000 fpm
(30.5 m/s)

Slot Fired

RECIRCULATING SYSTEMS

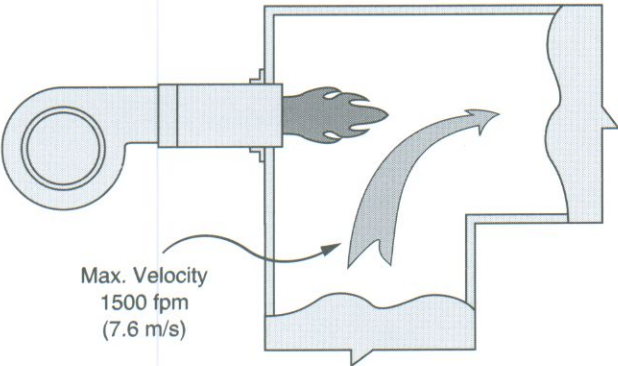

Max. Velocity
1500 fpm
(7.6 m/s)

Sealed Mounting.

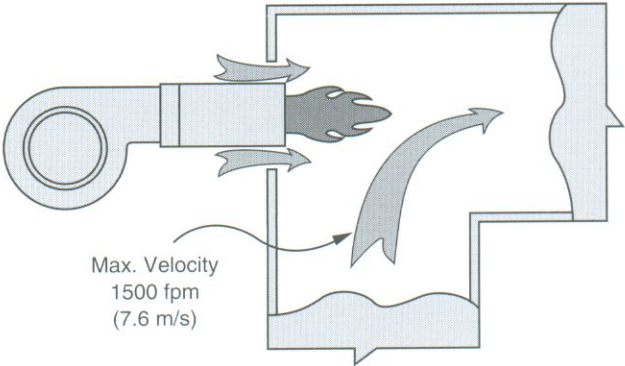

Max. Velocity
1500 fpm
(7.6 m/s)

Slot Fired

Standard Assembly

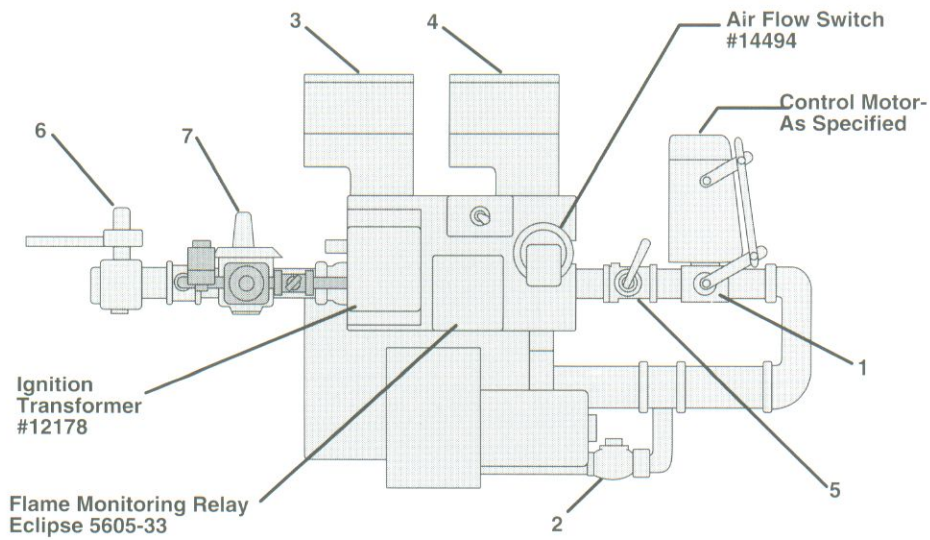

IRI Assembly

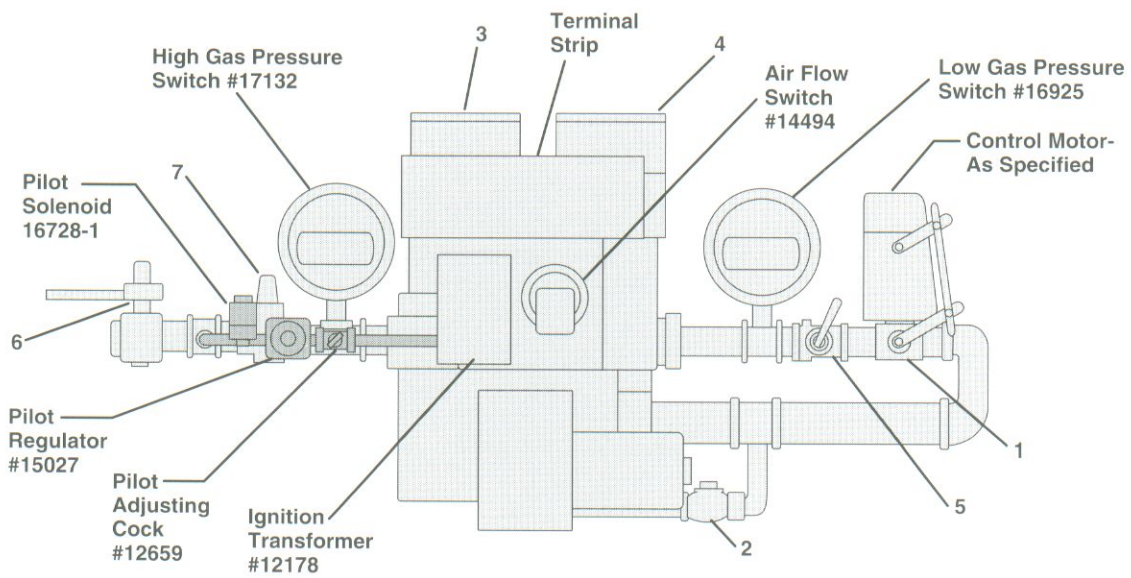

Parts List

Standard Assemblies

Item	Function	Description	50 HP	100 HP	150 HP	200 HP	250 HP	300 HP
1	Gas Control Valve	Butterfly Valve	500920	500920	500921	500921	500922	500922
2	Low Fire Check Valve	Eclipse	550088	550088	550092	550092	550096	550096
3	Auto Gas Shut-Off	As specified	---	---	---	---	---	---
4	Auto Gas Shut-Off	As specified	---	---	---	---	---	---
5	Manual Shut-Off	Gas Cock w/taps	19122	19122	14916	14916	14918	14918
6	Manual Shut-Off	Lubricated Gas Cock	19792	19792	19793	19793	19794	19794
7	Regulator	Maxitrol	12278	12278	12280	12282	12284	12284
—	Spark Plug	—	13047	13047	13047	13047	13047	13047
—	Flame Rod	—	13093	13093	13093	13093	13093	13093

IRI Assemblies

Item	Function	Description	50 HP	100 HP	150 HP	200 HP	250 HP	300 HP
1	Gas Control Valve	Butterfly Valve	500920	500920	500921	500922	500922	500923
2	Low Fire Check Valve	Eclipse	550088	550088	550092	550092	550096	550096
3	Auto Gas Shut-Off	As specified	---	---	---	---	---	---
4	Auto Gas Shut-Off	As specified	---	---	---	---	---	---
5	Manual Shut-Off	Gas Cock w/taps	19122	19122	14916	14918	14918	14926
6	Manual Shut-Off	Lubricated Gas Cock	19792	19792	19793	19794	19794	19795
7	Regulator	Maxitrol	12278	12278	12280	12284	12284	12285
—	Vent Valve	ASCO	16702-1	16702-1	16702-1	16702-1	16702-1	16702-2
—	Spark Plug	—	13047	13047	13047	13047	13047	13047
—	Flame Rod	—	13093	13093	13093	13093	13093	13093

Blower Motor Part Numbers

Burner Size	HP - RPM	115/1/60	230/460/3/60*
50	1/3 - 3450	11579	12109
100	1/3 - 3450	11579	12109
150	1/3 - 3450	11579	12109
200	1/3 - 1750	11754	12110
250	1/3 - 1750	11754	12110
300	1/3 - 1750	11754	12110

* Standard unless otherwise specified.

Overall Dimensions

See pg. 7 for mounting dimensions

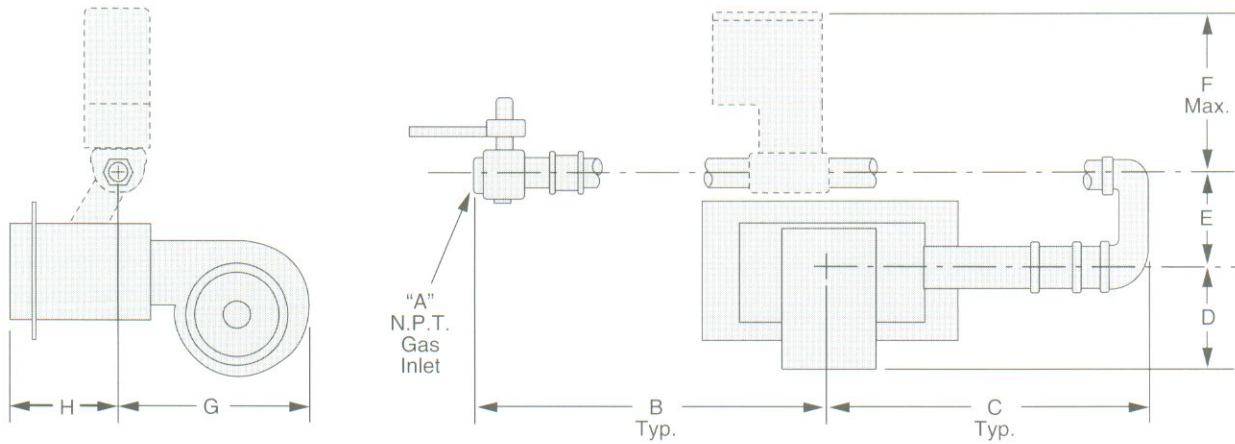

STANDARD BURNER—English Units

Catalog Number	Assembly Number	Dimensions In Inches							
		A	B	C	D	E	F	G	H
50 HP	109395	1	25-1/2	20	5-3/4	6-9/16	12-9/16	7-11/16	10-5/16
100 HP	109396	1	28-1/2	20	6-1/4	6-9/16	12-9/16	8-15/16	10-5/16
150 HP	109397	1-1/4	25-7/8	25	6-1/4	6-7/8	12-9/16	8-15/16	10-5/16
200 HP	109398	1-1/4	29-1/4	25	6-1/4	6-7/8	12-9/16	14-7/8	10-5/16
250 HP	109496	1-1/2	33-9/16	29	11-1/8	7-1/8	13-3/16	14-7/8	10-5/16
300 HP	109497	1-1/2	30-9/16	30-1/2	11-1/8	7-1/8	13-3/16	14-7/8	10-5/16

STANDARD BURNER—Metric Units

Catalog Number	Assembly Number	Dimensions In Millimeters							
		A	B	C	D	E	F	G	H
50 HP	109395	25	648	508	146	167	319	195	261
100 HP	109396	25	724	508	159	167	319	227	261
150 HP	109397	32	657	635	159	175	319	227	261
200 HP	109398	32	743	635	159	175	319	378	261
250 HP	109496	38	853	737	283	181	335	378	261
300 HP	109497	38	776	775	283	181	335	378	261

IRI BURNER—English Units

Catalog Number	Assembly Number	Dimensions In Inches							
		A	B	C	D	E	F	G	H
50 HP	109414	1	33	20	5-3/8	5-1/16	13-1/4	7-11/16	10-5/16
100 HP	109415	1	30	22	6-1/4	5-1/16	13-1/4	8-15/16	10-5/16
150 HP	109416	1-1/4	31-1/2	24-1/2	6-1/4	5-1/16	13-1/4	8-15/16	10-5/16
200 HP	109417	1-1/2	34	28	11-1/8	5-13/16	13-7/8	14-7/8	10-5/16
250 HP	109418	1-1/2	31	31	11-1/8	5-13/16	13-7/8	14-7/8	10-5/16
300 HP	109419	2	33-7/16	34-1/4	11-1/8	6	13-7/8	14-7/8	10-5/16

IRI BURNER—Metric Units

Catalog Number	Assembly Number	Dimensions In Millimeters							
		A	B	C	D	E	F	G	H
50 HP	109414	25	838	508	137	129	337	195	261
100 HP	109415	25	762	559	159	129	337	227	261
150 HP	109416	32	800	622	159	129	337	227	261
200 HP	109417	38	863	711	283	148	352	378	261
250 HP	109418	38	787	787	283	148	352	378	261
300 HP	109419	51	849	870	283	152	352	378	261

Mounting Dimensions

Burner with Flange

Standard: Non-Welded Flange
Optional: Welded Airtight Flange

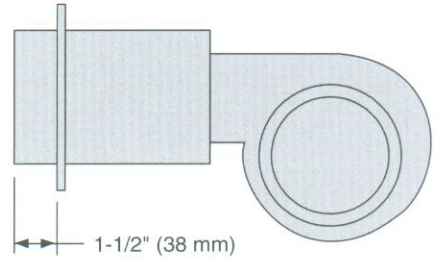
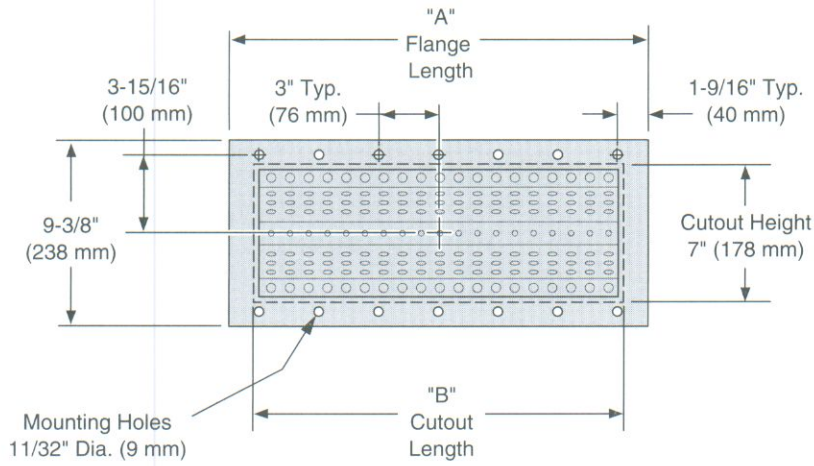

Burner with Optional Brackets for Slot-Firing

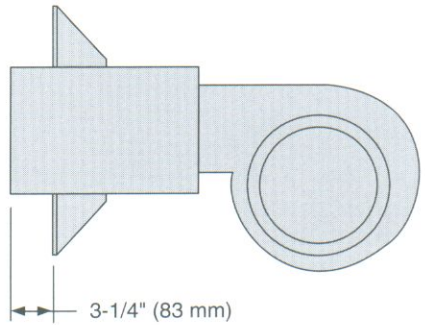
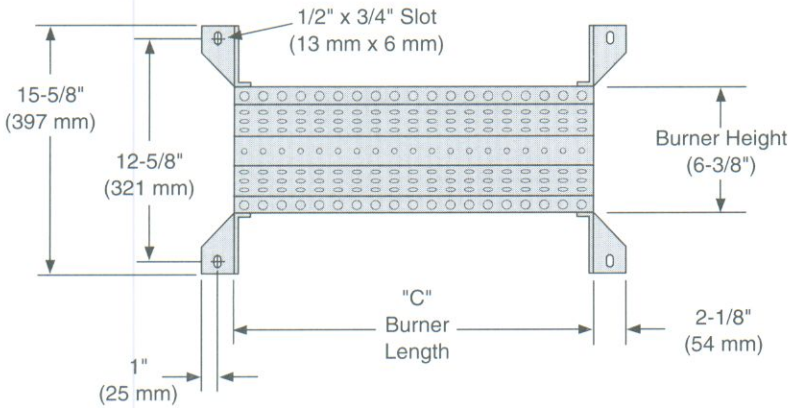

Burner Size	A		B		C	
	Inches	mm	Inches	mm	Inches	mm
50 HP	9-1/8	232	7-1/8	181	6-1/8	156
100 HP	15-1/8	384	13-1/8	333	12-1/8	308
150 HP	21-1/8	537	19-1/8	486	18-1/8	460
200 HP	27-1/8	689	25-1/8	638	24-1/8	613
250 HP	33-1/8	841	31-1/8	791	30-1/8	765
300 HP	39-1/8	994	37-1/8	943	36-1/8	918



Offered By:

Power Equipment Company
2011 Williamsburg Road
Richmond, Virginia 23231
Phone (804) 236-3800
Fax (804) 236-3882

www.peconet.com